

Solid State Start Switch (COMBINATION) Regaining Sweep Reverse (AMF 82-70)

For machines fitted with AMF MP chassis that have been converted from SS chassis operation or made prior to 1985.

This is an alternate for those of you experiencing braking problems with some versions of MP machines and some Omega-tek expander installations.

***** In some instances Sweep reverse may be lost after connecting the SS110C. To regain sweep reverse, just perform this simple modification.

Motors fitted with mechanical switches will continue to run as normal when this modification has been made.

Before modification:

Red wire from sweep motor is spliced to a wire that goes to C1-26BB
White wire from common terminal strip goes to motor start capacitors.
Wire from Sweep Reverse Switch goes to TS23.
Grey wire from C1-24T goes to TS23

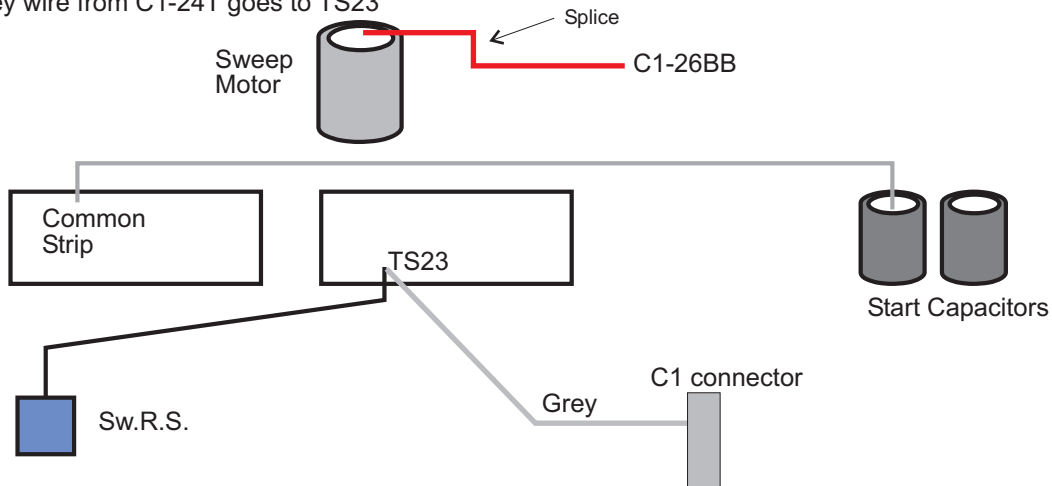

After Modification

Red wire from sweep motor goes to TS23.
White wire from motor start capacitors is spliced into the wire from C1-26BB
Wire from Sweep Reverse Switch goes to common terminal strip.
(Where white wire came from.)

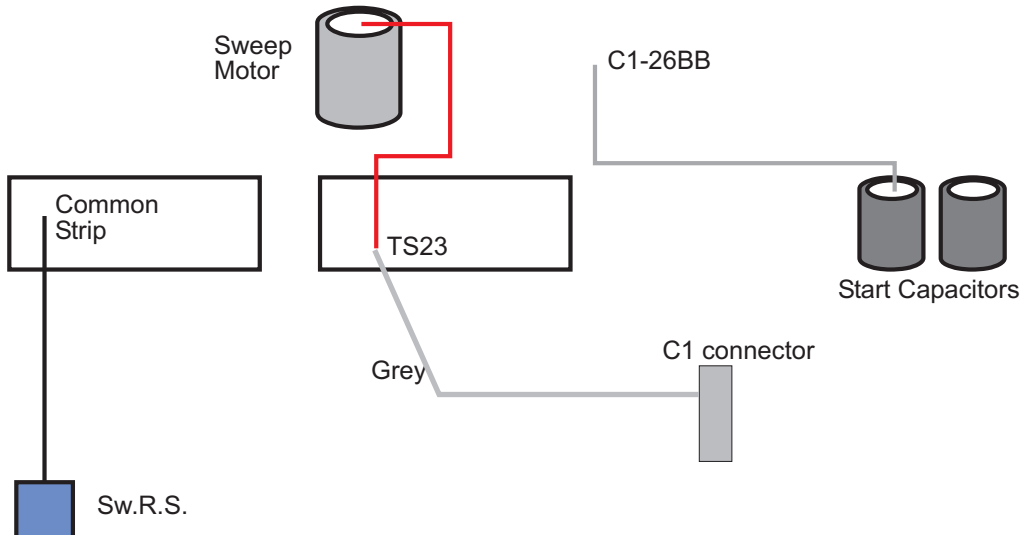

Many thanks to Paul Hawthorne from Sun Valley Lanes in Lincoln, Nevada USA for first testing this mod and bringing it to our attention.